

CASSPIR NG2000 MPV 4 x 4



Missions accomplished worldwide for more than 30 years it still provide you that peace of mind in protection. In 10 plus countries and 2800 manufactured, its more than just a Legacy it's a CASSPIR – Simplicity, Reliability and Quality – Your MPV of choice suitable for many applications.

CASSPIR®NG2000 is the flag ship of all CASSPIR vehicles – Everything and more that you need from a proven MPV.



MECHEM

DENEL LAND SYSTEMS





MERCEDES BENZ OM926LA



SPECIFICATIONS

Configuration	Designed for Military application
Rated Output	225 Kw @2300 rpm
Torque	1200 Nm @1200 rpm
Rated Hp	306 Hp
Displacement	7200 cm ₃
Number of Cylinders	6 In line
Exhaust Emission	EURO4

ENGINE SPECIFICATIONS

OM926LA identified for the CASSPIR NG2000 series is the latest development for specific Military application. This engine is also used in the Daimler Zetros Military Truck. Capable to operate with low quality Diesel and or Kerosene at an optimum operating performance of 2500m above sea level.

CASSPIR NG2000 with the OM906LA with special oil sump allow for a theoretical 100% grade climb ability. Engine had a fording ability of 1,2 m.

TRANSMISSION SYSTEM

VEHICLE OPTIONAL - MANUAL GEARBOX/TRANSMISSION



As for the CASSPIR NG2000 as an optional a Manual 9 speed transmission can be fitted with hydraulic pneumatic shift.

SPECIFICATIONS

Make/Type	G131-9
Forward Gears	8 + 1 Crawler gear

Vehicle Standard (Automatic Transmission)



Standard The Vehicle is equipped with Allison Automatic Shift that allow for driver comfort. Automatic shift is an 6 speed lockup system and widely in use on many Military equipment.

SPECIFICATIONS

Make/Type	Allison SP 3500
Forward Gears	6 with lockup.

TRANSFER CASE



CASSPIR NG2000 is fitted with a two range type transfer case for high and low range application. Out of the Mercedes Benz ZF stable a reliable and simple design allows the distribution of torque and drive to the front and rear axles of the vehicle suitable for the CASSPIR NG2000 series.

The transfer case allow for ample power to weight distribution to operate the CASSPIR NG series in off road and road conditions.

SPECIFICATIONS

Type	ZF VG1400-3W
Ratio -Road	1:1
Ratio – Off road	1:1691

PNEUMATIC SYSTEM

The CASSPIR NG2000 series is equipped with a dual circuit air brake system, equipped with ABS.

BRAKES

Service	Wabco 60l Dual Circuit Full-Air, drums all round
Emergency/Parking	Spring Brakes on Rear Wheels
Auxiliary	Remote mounted engine exhaust brake

WHEELS AND TYRES



CASSPIR®NG2000 come as standard with M-Type Wheels to the size of 14:00 x 20 18 ply.

The CASSPIR is equipped with 4 wheels + 2 wheels for spare.

Optional Run Flat Wheels can be fitted to the CASSPIR NG series as a non standard and optional to the base product.

SPECIFICATIONS	(Standard)
Rims	Standard Steel Mil Type Rim.
Tyres Type	M-Type
Tyre Size Front	14:00 X20 Single
Tyre Size Rear	14:00X20 Single
Spare Wheel Qty	2
Spare Wheel Type	14:00x20 – same spec as Vehicle wheels.

AXLES & SUSPENSION

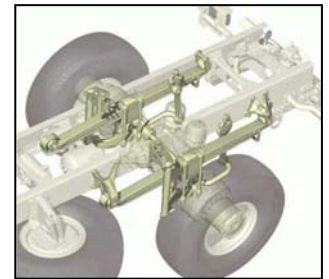

CASSPIR NG2000 is equipped with the well known MB heavy duty axles, built to specifications in Daimler AG and Switzerland. Both axles fitted to CASSPIR NG series are of similar variant as used in the Mercedes Zetros Military Truck of a high axle load carrying capacity. CASSPIR NG2000 is fitted with a 9000 kg load carry capacity axles that allows for potential armour upgrade without vehicle overloading.

FRONT AXLE

Type	AL7/DS-9
Suspension	Axle suspension with longitudinal leaf springs with stabilizer bars and dampers
Axle Load	9000kg

REAR AXLE

Type	HL7/DS-13
Suspension	Axle suspension with longitudinal leaf springs with stabilizer bars and dampers
Axle Load	13000kg Double Wheels & 9000Kg Single wheel operation

STEERING

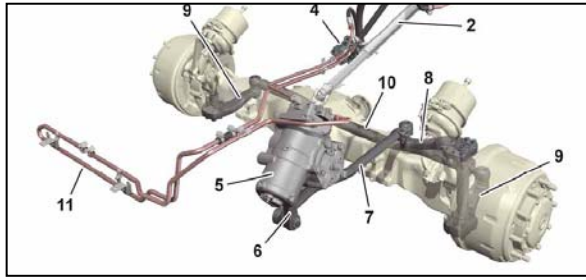

CASSPIR NG2000 can be either Left or right hand drive. Steering is a single circuit hydraulic operation .Fitted with a ZF8098 Steering box. The system provides excellent turning capability with a turning radius of 8 m.

AIR CLEANER SYSTEM

CASSPIR NG2000 is fitted with a Donaldson dry paper element Air cleaner

ELECTRICAL EQUIPMENT

Alternator	2 x 210A & 255A
Starter	24V – 5,4kW
Batteries	2 x 12V, 120Ah

CHASSIS

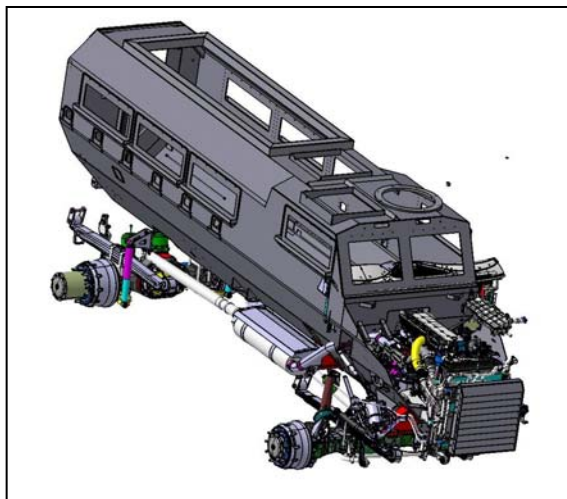

CASSPIR design is based on a welded V-Shape Moncouque principle that exclude the use of a standard conventional chassis as for a normal heavy duty truck. The design allow for the fitment and bolt on of axles and suspension part direct to the vehicle body

HULL



One piece welded and bend single construction V-shaped Mine protected Hull comply to STANAG 4569

SPECIFICATIONS

(Standard)

Steel Type	Swedish Armour Armox
Level	Level 1 & B6 + standard
STANAG 4569	Level 4a and 4b



INSTRUMENTS

Standard interior vehicle Instruments that include speedo/odometer, revolution counter, fuel, engine, temp and oil pressure gauges.

VEHICLE	DIMENSIONS
Gross Vehicle Weight	14300kg
Towing Capacity	13500kg
Wheel base	4200mm
Overall length	77756mm
Overall Height	2903mm*
Overall width	2733mm
Hump Radius	R2800
Ground Clearance	350mm
Turning Radius	16m
Step Height climb	500mm
Ditch Crossing	800mm
Fording depth	800mm
Angle of Approach	33°
Angle of Departure	50°
Tilting Permitted	26°*

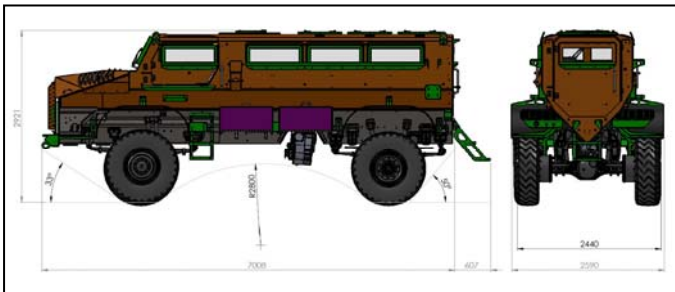

PERFORMANCE DATA

Speed	100km/h
Climbing Capability	60%
Road Range	700 to 800Km
Off road Range	600Km

BALISTIC AND MINE PROTECTION DATA

Mine Protection Hull	14kg Blast under Hull
Mine Protection Wheel	21Kg blast under any Wheel
Level	B6 7,62mm x 51
STANAG KE	4569 L3
STANAG BLAST	4569 L4a & L4b

WINDOWS

CASSPIR NG2000 is fitted with ballistic tested polycarbonate laminated layered bullet resistant windows. Integrated within the window a gun port encased in a rubber with the complete window fitted to a frame.

INTERIOR



Large open interior with design features to shift the seat configuration as to client requirement. All seats are of the latest and tested ballistic type fitted with a 4 point safety harness system.

VEHICLE EXTERIOR



Vehicle is fitted with two crew side doors and one rear entry exit door. A drinking water tank, two stowage lockable boxes and a battery box are all fitted to the side of the vehicle.



- Various 3rd party - Turret systems for integration
- Additional Armour to B7 7,62 mm x 54 API
- Remote Operated Single Weapon Nato Type Turret System
- RFI Wheels

CASSPIR VARIANTS

- CASSPIR Recovery 4 x 4 Medium & 6x6 Heavy
- CASSPIR Ambulance 4 x 4 (4 Patient Transport)
- CASSPIR Command 4 x 4
- CASSPIR Weapon Platform 4 x 4 (AA and Indirect)
- CASSPIR Logistics 4 x 4 Cargo, Fuel Water etc.)

STANDARD ACCESSORIES

- Heavy Duty Double Air Conditioner System
- Toolbox with Tools
- Jack, Wheel-spanner and remote tyre inflator.
- Spade, Axe and Pick
- Tow bar
- Wheel Hub protection plates
- 14:00 x 20 Multi-Purpose Wheels
- Front Mounted Light Obstacle Recovery Winch.

OPTIONAL ACCESSORIES

- Side Weapon NATO 7,62 mm Pintle mounts.
- Light Turret – Nato 7,62 Standard
- Automatic Transmission – Allison SP3000 Series





DENEL LAND SYSTEMS



DENEL LAND SYSTEMS, a division of Denel SOC Ltd.
PO Box 7710
Pretoria
0001
South Africa.

International Tel: +27 12 620 9111
Fax: +27 12 620 3466
E-mail: marketing@dlsys.co.za
Web: <http://www.denellandsystems.co.za>

NOTE: Subject to improvement or change without prior notice. The document is issued for information only and shall not be deemed to form part of any contract